

**HPSD 3000 Pressure Transducer****General description**

Pressure transducer HPSD 3000 is an OEM pressure sensing device. Signal conditioning consists of complete temperature compensation and adjusted amplifier in single, programmable ASIC. High performance and accuracy enables use of this transducer in many applications. Programmable temperature compensation provides 1% total error over 0 to 70°C temperature range. Operating from single 5 V supply, wide compensated temperature range and standard, ratiometric 0.5 to 4.5 V output provides OEM users maximum freedom for any type of application with dry air or non-corrosive gases or liquids.

The model HPSD 3000 is designed for through hole PCB assembly with one or two pressure tubes. The whole group consists for pressure ranges from 10 mbar to 7 bar. Gage, differential and absolute versions are available for this group.

**Features**

- Single 5 V supply voltage
- Easy to use package
- Wide compensated range (0 to 70°C)
- Total accuracy down to 1% over 0 to 70°C, all effects included (maximum)
- Standard 0.5 – 4.5 V voltage output
- Up to 15 bits I2C output (pressure + temperature)
- High performance OEM applications
- Gage, differential and absolute pressure configurations

**Applications**

- HVAC
- Medical instrumentation
- Respirators
- Air flow monitoring
- Process control
- Leak detection
- Altimeters

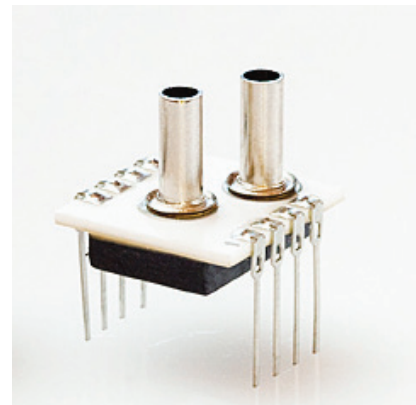

This information applies to a product under development. Its characteristics and specifications are subject to change without notice. Hyb d.o.o. assumes no obligation regarding future manufacture unless otherwise agreed to in writing. Copyright © Hyb d.o.o., 2010. All rights reserved.

**Available types overview**

$T_{AMB} = 25^{\circ}\text{C}$

$V_{CC} = 5\text{ V, unless otherwise noted}$

**Low pressure range**

Pressure range	10 mbar (0.15 psi)	20 mbar (0.3 psi)	50 mbar (0.8 psi)	100 mbar (1.5 psi)
ID group	HPSD 3000-010M	HPSD 3000-020M	HPSD 3000-050M	HPSD 3000-100M
Pressure types	differential/gage bidirectional differential	differential/gage bidirectional differential	differential/gage bidirectional differential	differential/gage bidirectional differential
V <sub>OUT</sub>	0.5 to 4.5 V	0.5 to 4.5 V	0.5 to 45 V	0.5 to 4.5 V
Temperature ranges	Operating: -25 to 85°C Compensated: 0 to 70°C Storage : -40 to 125°C			
Over pressure <sup>1)</sup>	100 mbar	200 mbar	500 mbar	1000 mbar
Burst pressure <sup>2)</sup>	150 mbar	300 mbar	750 mbar	1500 mbar

**High pressure range**

Pressure range	350 mbar (5 psi)	1 bar (15 psi)	2 bar (30 psi)	4 bar (60 psi)	7 bar (100 psi)
ID group	HPSD 3000-350M	HPS D3000-001B	HPSD 3000-002B	HPSD 3000-004B	HPSD 3000-007B
Pressure types	differential/gage bidirectional differential	differential/gage bidirectional differential absolute	differential/gage bidirectional differential absolute	differential/gage bidirectional differential absolute	differential/gage bidirectional differential absolute
V <sub>OUT</sub>	0.5 to 4.5 V	0.5 to 4.5 V	0.5 to 4.5 V	0.5 to 4.5 V	0.5 to 4.5 V
Temperature ranges	Operating: -25 to 85°C Compensated: 0 to 70°C Storage : -40 to 125°C				
Over pressure <sup>1)</sup>	1 bar	3 bar	6 bar	8 bar	14 bar
Burst pressure <sup>2)</sup>	1.7 bar	5 bar	10 bar	12 bar	21 bar

This information applies to a product under development. Its characteristics and specifications are subject to change without notice. Hyb d.o.o. assumes no obligation regarding future manufacture unless otherwise agreed to in writing. Copyright © Hyb d.o.o., 2010. All rights reserved.

### Performance characteristics

$$T_{AMB} = 25^{\circ}\text{C}$$

$$V_{CC} = 5\text{ V, unless otherwise noted}$$

Parameter	Symbol	Min.	Type	Max.	Unit
<b>Power supply</b>					
Supply voltage	$V_{CC}$	4.75		5.25	V
Current consumption	$I_{CC}$		4	6.5	mA
<b>Analog output (pressure) <sup>3)</sup></b>					
Offset voltage <sup>4)</sup>	$V_O$		0,50		V
Full scale output (FSO) <sup>5)</sup>	$V_{FS}$		4,50		V
Full scale span (FSS) <sup>6)</sup>	$V_{FSO}$		4,00		V
Offset voltage (bidirectional devices)	$V_O$		2,50		V
<b>Digital output (pressure), 15 bits <sup>3)</sup></b>					
Offset voltage <sup>4)</sup>	$V_O$		3277		counts
Full scale output (FSO) <sup>5)</sup>	$V_{FS}$		29491		counts
Full scale span (FSS) <sup>6)</sup>	$V_{FSO}$		26214		counts
Offset voltage (bidirectional devices)	$V_O$		16384		counts
<b>Digital output (temperature), 15 bits <sup>7)</sup></b>					
Temperature output @ 0°C	$T_o$		8192		counts
Temperature output @ 70°C	$T_s$		24576		counts
<b>Accuracy (pressure) @ 25°C <sup>8)</sup></b>					
Low pressure (10 mbar FS devices)	$E_a$			±2	%FSO
Low pressure (20 to 100 mbar FS devices)	$E_a$			±1.5	%FSO
Standard pressure	$E_a$			±0.8	%FSO
<b>Total accuracy (pressure) @ 0 to 70°C <sup>9)</sup></b>					
Low pressure (10 mbar FS devices)	$E_{ta}$			±2.5	%FSO
Low pressure (20 to 100 mbar FS devices)	$E_{ta}$			±2	%FSO
Standard pressure (all other devices)	$E_{ta}$			±1	%FSO
<b>Resolution</b>					
A/D converter	$D_i$			15	bit
D/A converter	$D_o$		11		bit
Response time	$E_{rt}$		1.5		ms
Repeatability <sup>10)</sup>	$E_r$		±0.05		% FSO
Nonlinearity & pressure hysteresis (BFSL) <sup>11)</sup>	$E_l$		±0.1	±0.3	% FSO
Load resistance	$R_L$	2		∞	k
Media compatibility		See spec. note <sup>12), 13)</sup>			
Weight	W		3		g

This information applies to a product under development. Its characteristics and specifications are subject to change without notice. Hyb d.o.o. assumes no obligation regarding future manufacture unless otherwise agreed to in writing. Copyright © Hyb d.o.o., 2010. All rights reserved.

## Specification notes

- 1) Over pressure is the maximum pressure which may be applied without causing damage to the sensing element.
- 2) Burst pressure is the maximum pressure which may be applied without causing leakage damage to the sensing element.
- 3) Analog output signal is ratiometric to power supply  $V_{cc}$ , digital signal is not ratiometric to the power supply.
- 4) Offset voltage is the voltage output at zero pressure.
- 5) Full scale output is the voltage output at full pressure range.
- 6) Full scale span is the algebraic difference between the output at full scale pressure range and offset.
- 7) Digital output signal (temperature) is not ratiometric to power supply  $V_{cc}$ . Temperature data are read directly on the sensing element.
- 8) Accuracy includes all effects (offset, span, nonlinearity, pressure hysteresis and repeatability) at room temperature and represents maximum deviation of transducer signal from ideal characteristic.
- 9) Total accuracy includes all effects (offset, span, nonlinearity, pressure hysteresis and repeatability) included with all temperature effects of offset and span. It describes overall error and represents maximum deviation of transducer signal from ideal characteristic in compensated temperature range from 0 to 70°C.
- 10) Repeatability is defined as typical deviation of the output signal after 10 pressure cycles.
- 11) Nonlinearity is defined as the BFSL (best fit straight line) across entire pressure range.
- 12) Media compatibility: on pressure port P1: clean, dry and noncorrosive gases to silicon, RTV, gold, ceramics  $Al_2O_3$ , epoxy, nickel.
- 13) Media compatibility: on pressure port P2: noncorrosive gases or liquids to silicon, Pyrex, RTV, ceramics  $Al_2O_3$ , epoxy, nickel.

## I2C communication

### General description

HPSD 3000 pressure transducer have I2C communication availability. When this device is connected to bidirectional I2C digital bus, the digital readouts with resolution up to 15 bits of pressure (1<sup>st</sup> and 2<sup>nd</sup> byte) and temperature (3<sup>rd</sup> and 4<sup>th</sup> byte) can be read from serial register of the internal ASIC.

HPSD 3000 works as a slave configured device which replies to the requests from the master (normally microcontroller). The I2C bus is controlled from the master which generates START and STOP conditions.

### Digital I2C interface

States descriptions:

**Idle period:** the bus is free when both data line (SDA) and clock line (SCL) are HIGH.

**START condition (S):** is generated in transition of SDA line from HIGH(H) to LOW(L) when SCL line (clock) is HIGH. It can be only generated by the master. Each data request needs to starts with START condition.

This information applies to a product under development. Its characteristics and specifications are subject to change without notice. Hyb d.o.o. assumes no obligation regarding future manufacture unless otherwise agreed to in writing. Copyright © Hyb d.o.o., 2010. All rights reserved.

**STOP condition (P):** is generated in transition of SDA line from LOW(H) to HIGH(L) when SCL line (clock) is HIGH. It can be only generated by the master. Each data request needs to end with STOP condition.

**DATA valid (D):** Data is transmitted in bytes (8 bits) starting with pressure data (2 bytes) with the MSB (most significant bit) first and followed by 2 bytes of temperature data with MSB first. Each data bit is transferred with each clock pulse. Valid data are presented after start condition when data line is stable during HIGH clock is generated. SDA changes must be done while clock is LOW.

**ACKNOWLEDGE (A):** Information data are transferred in bytes (8 bits) on data bus with MSB first. After receiving of each byte master or slave must pull down SDA line to LOW as acknowledge for receiving the data. For that reason master must generate an extra clock. If acknowledge is missed slave becomes inactive, which means that master must either repeat last command or to generate STOP condition.

**SLAVE address:** Default slave address of HPSD 3000 devices are factory calibrated to 0x78. According to I2C specification there are 127 different addresses available, which give possibility for multi-slave communication where the user can connect up to 127 devices with unique addresses to the same I2C bus. After generating START condition master sends address containing 7 bits followed by a R/W (read="1", write="0").

I2C communication protocol:

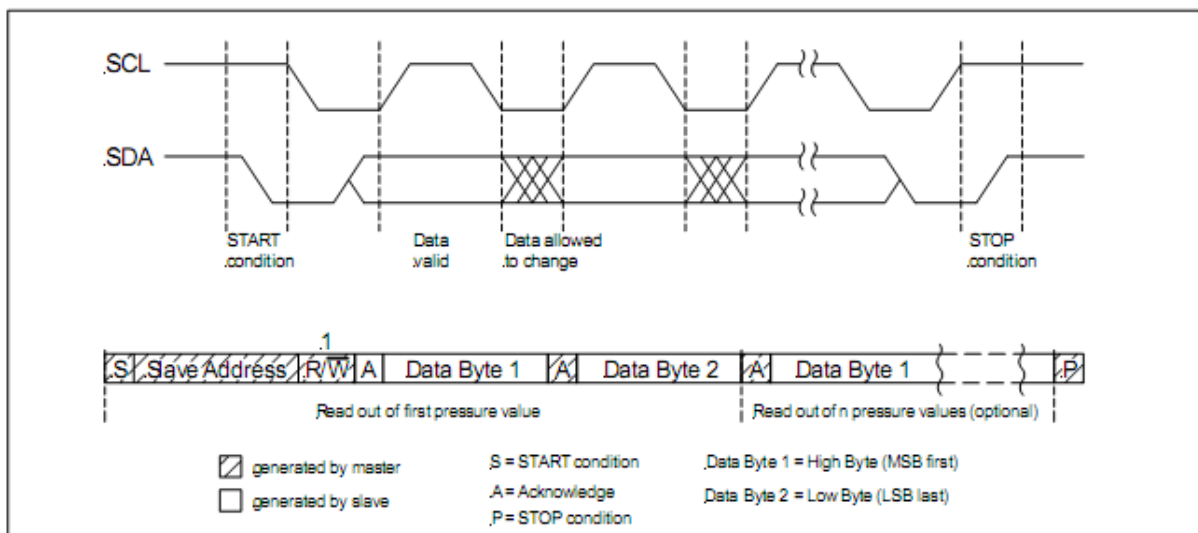

This information applies to a product under development. Its characteristics and specifications are subject to change without notice. Hyb d.o.o. assumes no obligation regarding future manufacture unless otherwise agreed to in writing. Copyright © Hyb d.o.o., 2010. All rights reserved.

I2C interface parameters:

Parameter	Min.	Max.	Unit
Input HIGH level	90	100	%V <sub>CC</sub>
Input LOW level	0	10	%V <sub>CC</sub>
Output LOW level		10	%V <sub>CC</sub>
Pull up resistor	700		Ω
Clock frequency SCL	100	400	kHz
Load capacitance (SDA)		400	pF
Input capacitance (SCL/SDA)		10	pF

I2C application circuit:

Both I2C lines have to be connected to V<sub>CC</sub> with pull up resistors (recommended 4.7 k ohms), additional serial resistors 300 ohms recommended also (optional).

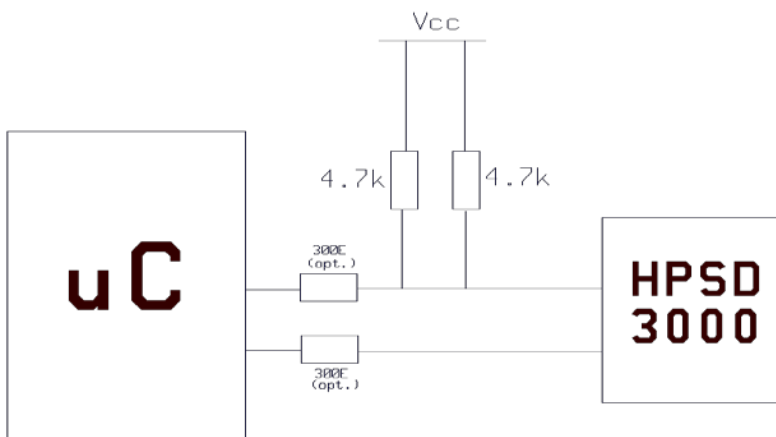

This information applies to a product under development. Its characteristics and specifications are subject to change without notice. Hyb d.o.o. assumes no obligation regarding future manufacture unless otherwise agreed to in writing. Copyright © Hyb d.o.o., 2010. All rights reserved.

**Outline dimensions and pinout**

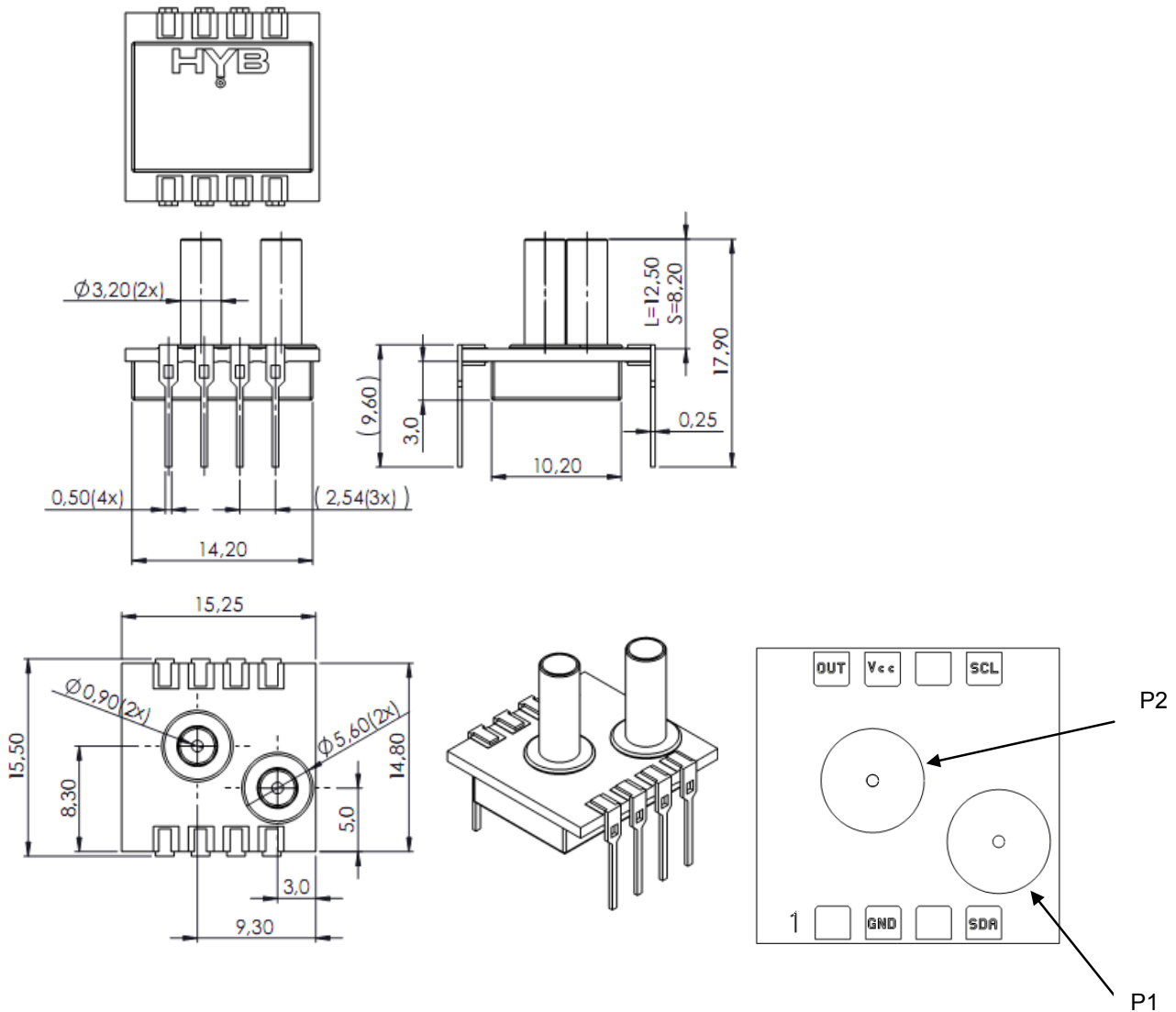

Note: positive pressure to port P1

This information applies to a product under development. Its characteristics and specifications are subject to change without notice. Hyb d.o.o. assumes no obligation regarding future manufacture unless otherwise agreed to in writing. Copyright © Hyb d.o.o., 2010. All rights reserved.

Ordering guide

Transducer type	Pressure range	Pressure type	Pressure direction	Pressure port	Pressure tube
HPSD 3000	010M	D	0	P	S
	020M	G	B	N	L
	050M	A			
	100M				
	350M				
	001B				
	002B				
	004B				
	007B				

Pressure range	
010M	10 mbar
020M	20 mbar
050M	50 mbar
100M	100 mbar
350M	350 mbar
001B	1 bar
002B	2 bar
004B	4 bar
007B	7 bar

Pressure type	
D	Differential
G	Gage
A	Absolute (for $p \geq 1$ bar)

Pressure tube	
S	SHORT (8.3mm)
L	LONG (12.5mm)

Pressure direction	
0	0 to press. range
B	-press range to +press. range (bidirectional)

Pressure port	
P	Positive pressure on P1
N	Negative pressure on P1

Other configurations possible on special request.

This information applies to a product under development. Its characteristics and specifications are subject to change without notice. Hyb d.o.o. assumes no obligation regarding future manufacture unless otherwise agreed to in writing. Copyright © Hyb d.o.o., 2010. All rights reserved.