

HPSD 2000 Pressure Transducer**General description**

Pressure transducer HPSD 2000 is a pressure sensing device. High performance and accuracy enables use of this transducer in many applications. The HPSD 2000 pressure transducers are constructed on 1 mm thick ceramic substrate attached inside standard metal 19 mm housing with O-ring groove. Input pressure is sensed with silicon piezoresistive bridge. Programmable temperature compensation provides 1% total error over 0 to 70°C temperature range. Operating from single 5 V supply, wide compensated temperature range and standard, ratiometric 0.5 V to 4.5 V output provides OEM users maximum freedom for any type of application with dry air or non-corrosive gases and liquids.

Whole family HPSD 2000 includes 20 mbar up to 7 bar pressure range.

Features

- Single 5 V supply voltage
- Easy to use package
- Wide compensated range (0 to 70°C)
- Up to 15 bits I2C output (pressure + temperature)
- Standard 0.5 to 4.5 V voltage output
- Total accuracy down to 1% over 0 to 70°C, all effects included (maximum)
- High performance OEM applications
- Integrated EMC protection
- Gage configuration

Applications

- Industrial Process Control
- Transducer voltage transmitter
- Air flow monitoring
- Process control
- Leak detection

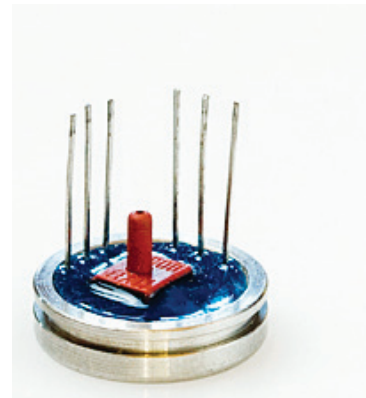

This information applies to a product under development. Its characteristics and specifications are subject to change without notice. Hyb d.o.o. assumes no obligation regarding future manufacture unless otherwise agreed to in writing. Copyright © Hyb d.o.o., 2010. All rights reserved.

HPSD 2000 Pressure Transducer

Types overview

$$T_{AMB} = 25^{\circ}\text{C}$$

$$V_{CC} = 5\text{ V, unless otherwise noted}$$

Low pressure range

Pressure range	20 mbar (0.3 psi)	50 mbar (0.8 psi)	100 mbar (1.5 psi)
ID group	HPSD 2000-020M	HPSD 2000-050M	HPSD 2000-100M
V _{OUT}	0.5 to 4.5 V	0.5 to 4.5 V	0.5 to 4.5 V
Temperature ranges	Operating: -25 to 85°C Compensated: 0 to 70°C Storage : -40 to 125°C		
Over pressure	200 mbar	500 mbar	1000 mbar
Burst pressure	300 mbar	750 mbar	1500 mbar

High pressure range

Pressure range	350 mbar (5psi)	1 bar (15psi)	2 bar (30psi)	4 bar (60psi)	-1 to 0 bar (vacuum)
ID group	HPSD 2000-350M	HPSD 2000-001B	HPSD 2000-002B	HPSD 2000-004B	HPSD 2000-000B
V _{OUT}	0.5 to 4.5 V	0.5 to 4.5 V	0.5 to 4.5 V	0.5 to 4.5 V	0.5 to 4.5 V
Temperature ranges	Operating: -25 to 110°C Compensated: 0 to 70°C Storage : -40 to 125°C				
Over pressure	1 bar	3 bar	6 bar	8 bar	3 bar
Burst pressure	1.7 bar	5 bar	10 bar	12 bar	5 bar

This information applies to a product under development. Its characteristics and specifications are subject to change without notice. Hyb d.o.o. assumes no obligation regarding future manufacture unless otherwise agreed to in writing. Copyright © Hyb d.o.o., 2010. All rights reserved.

Performance characteristics

$T_{AMB} = 25^{\circ}\text{C}$
 $V_{CC} = 5\text{ V}$, unless otherwise noted

Parameter	Symbol	Min.	Type	Max.	Unit
Power supply					
Supply voltage	V_{CC}	4.75		5.25	V
Current consumption	I_{CC}		4	6.5	mA
Analog output (pressure)³⁾					
Offset voltage ⁴⁾	V_O		0,50		V
Full scale output (FSO) ⁵⁾	V_{FS}		4,50		V
Full scale span (FSS) ⁶⁾	V_{FSO}		4,00		V
Offset voltage (bidirectional devices)	V_O		2,50		V
Digital output (pressure), 15 bits³⁾					
Offset voltage ⁴⁾	V_O		3277		counts
Full scale output (FSO) ⁵⁾	V_{FS}		29491		counts
Full scale span (FSS) ⁶⁾	V_{FSO}		26214		counts
Offset voltage (bidirectional devices)	V_O		16384		counts
Digital output (temperature), 15 bits⁷⁾					
Temperature output @ 0°C	T_o		8192		counts
Temperature output @ 70°C	T_s		24576		counts
Accuracy (pressure) @ 25°C⁸⁾					
Low pressure (20 to 100 mbar FS devices)	E_a			±1.5	%FSO
Standard pressure	E_a			±0.8	%FSO
Total accuracy (pressure) @ 0 to 70°C⁹⁾					
Low pressure (20 to 100 mbar FS devices)	E_{ta}			±2	%FSO
Standard pressure (all other devices)	E_{ta}			±1	%FSO
Resolution					
A/D converter	D_i			15	bit
D/A converter	D_o		11		bit
Response time	E_{rt}		1.5		ms
Repeatability ¹⁰⁾	E_r		±0.05		% FSO
Nonlinearity & pressure hysteresis (BFSL) ¹¹⁾	E_l		±0.1	±0.3	% FSO
Load resistance	R_L	2		∞	k
Media compatibility			See spec. note ¹²⁾		
Weight	W		9		g

This information applies to a product under development. Its characteristics and specifications are subject to change without notice. Hyb d.o.o. assumes no obligation regarding future manufacture unless otherwise agreed to in writing. Copyright © Hyb d.o.o., 2010. All rights reserved.

Specification notes

- 1) Over pressure is the maximum pressure which may be applied without causing damage to the sensing element.
- 2) Burst pressure is the maximum pressure which may be applied without causing leakage damage to the sensing element.
- 3) Analog output signal is ratiometric to power supply V_{cc} , digital signal is not ratiometric to the power supply.
- 4) Offset voltage is the voltage output at zero pressure.
- 5) Full scale output is the voltage output at full pressure range.
- 6) Full scale span is the algebraic difference between the output at full scale pressure range and offset.
- 7) Digital output signal (temperature) is not ratiometric to power supply V_{cc} . Temperature data are read directly on the sensing element.
- 8) Accuracy includes all effects (offset, span, nonlinearity, pressure hysteresis and repeatability) at room temperature and represents maximum deviation of transducer signal from ideal characteristic.
- 9) Total accuracy includes all effects (offset, span, nonlinearity, pressure hysteresis and repeatability) included with all temperature effects of offset and span. It describes overall error and represents maximum deviation of transducer signal from ideal characteristic in compensated temperature range from 0 to 70°C.
- 10) Repeatability is defined as typical deviation of the output signal after 10 pressure cycles.
- 11) Nonlinearity is defined as the BFSL (best fit straight line) across entire pressure range.
- 12) Media compatibility: clean, dry and noncorrosive gases and liquids to pyrex, silicon, RTV, ceramics Al_2O_3 , epoxy, stainless steel.

I2C communication

General description

HPSD 2000 pressure transducers have I2C communication availability. When this device is connected to bidirectional I2C digital bus, the digital readouts with resolution up to 15 bits of pressure (1st and 2nd byte) and temperature (3rd and 4th byte) can be read from serial register of the internal ASIC.

HPSD 2000 works as a slave configured device which replies to the requests from the master (normally microcontroller). The I2C bus is controlled from the master which generates START and STOP conditions.

Digital I2C interface

States descriptions:

Idle period: the bus is free when both data line (SDA) and clock line (SCL) are HIGH.

START condition (S): is generated in transition of SDA line from HIGH(H) to LOW(L) when SCL line (clock) is HIGH. It can be only generated by the master. Each data request needs to starts with START condition.

This information applies to a product under development. Its characteristics and specifications are subject to change without notice. Hyb d.o.o. assumes no obligation regarding future manufacture unless otherwise agreed to in writing. Copyright © Hyb d.o.o., 2010. All rights reserved.

STOP condition (P): is generated in transition of SDA line from LOW(H) to HIGH(L) when SCL line (clock) is HIGH. It can be only generated by the master. Each data request needs to end with STOP condition.

DATA valid (D): Data is transmitted in bytes (8 bits) starting with pressure data (2 bytes) with the MSB (most significant bit) first and followed by 2 bytes of temperature data with MSB first. Each data bit is transferred with each clock pulse. Valid data are presented after start condition when data line is stable during HIGH clock is generated. SDA changes must be done while clock is LOW.

ACKNOWLEDGE (A): Information data are transferred in bytes (8 bits) on data bus with MSB first. After receiving of each byte master or slave must pull down SDA line to LOW as acknowledge for receiving the data. For that reason master must generate an extra clock. If acknowledge is missed slave becomes inactive, which means that master must either repeat last command or to generate STOP condition.

SLAVE address: Default slave address of HPSD 2000 devices are factory calibrated to 0x78. According to I2C specification there are 127 different addresses available, which gives possibility for multi-slave communication where the user can connect up to 127 devices with unique addresses to the same I2C bus. After generating START condition master sends address containing 7 bits followed by a R/W (read="1", write="0").

I2C communication protocol:

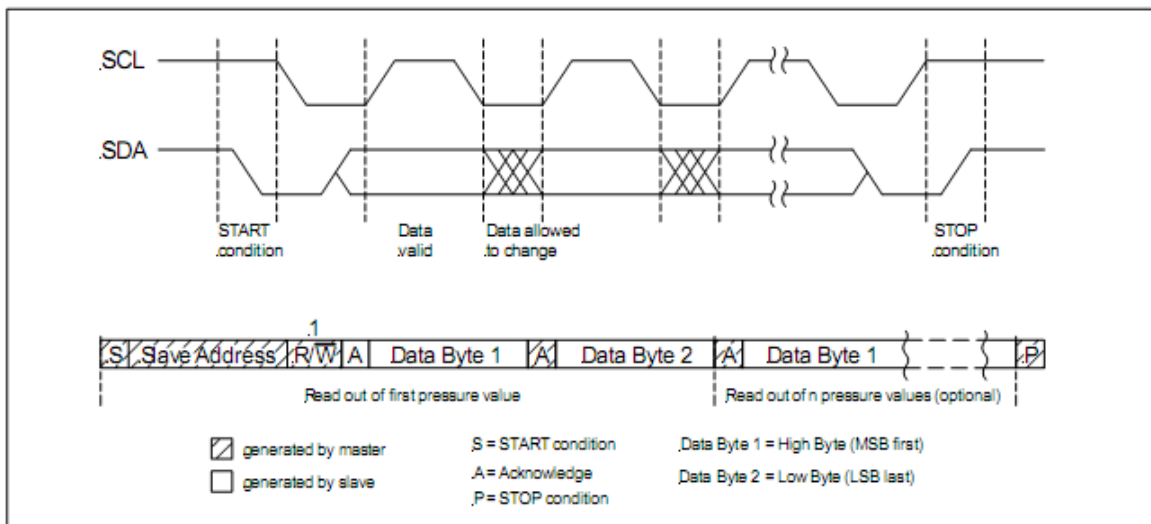

This information applies to a product under development. Its characteristics and specifications are subject to change without notice. Hyb d.o.o. assumes no obligation regarding future manufacture unless otherwise agreed to in writing. Copyright © Hyb d.o.o., 2010. All rights reserved.

I2C interface parameters:

Parameter	Min.	Max.	Unit
Input HIGH level	90	100	%V _{cc}
Input LOW level	0	10	%V _{cc}
Output LOW level		10	%V _{cc}
Pull up resistor	700		Ω
Clock frequency SCL	100	400	kHz
Load capacitance (SDA)		400	pF
Input capacitance (SCL/SDA)		10	pF

I2C application circuit:

Both I2C lines have to be connected to V_{cc} with pull up resistors (recommended 4.7k ohms), additional serial resistors 300 ohms recommended also (optional).

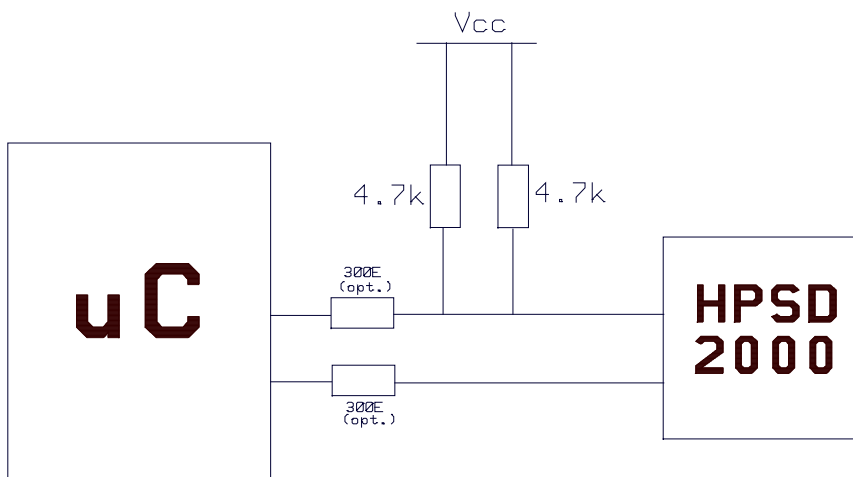

This information applies to a product under development. Its characteristics and specifications are subject to change without notice. Hyb d.o.o. assumes no obligation regarding future manufacture unless otherwise agreed to in writing. Copyright © Hyb d.o.o., 2010. All rights reserved.

Outline dimensions

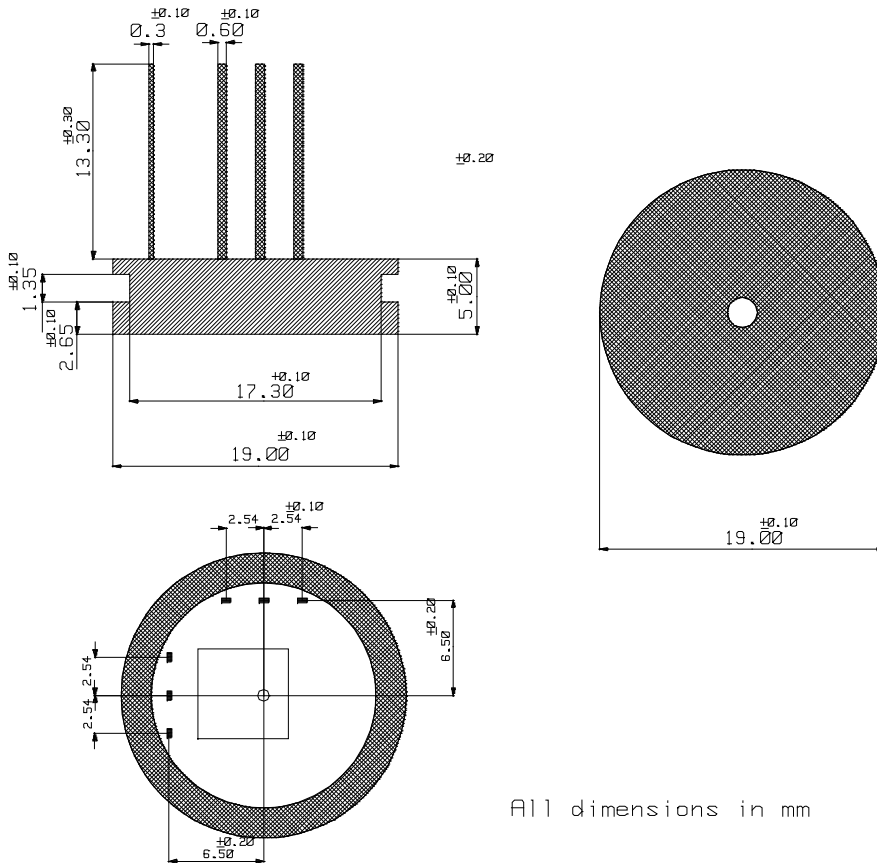

All dimensions in mm

Pinout

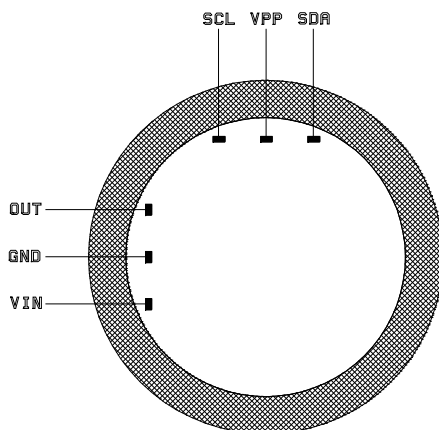

This information applies to a product under development. Its characteristics and specifications are subject to change without notice. Hyb d.o.o. assumes no obligation regarding future manufacture unless otherwise agreed to in writing. Copyright © Hyb d.o.o., 2010. All rights reserved.

Ordering guide

Transducer type	Pressure range	Pressure type	Pressure direction
HPSD 2000	020M	G	0
	050M		B
	100M		
	350M		
	001B		
	002B		
	004B		
	007B		
	000B		

Pressure range	
020M	20 mbar
050M	50 mbar
100M	100 mbar
350M	350 mbar
001B	1 bar
002B	2 bar
004B	4 bar
007B	7 bar
000B	vacuum

Pressure type	
G	Gage

Pressure direction	
0	0 to press. range
B	-press range to +press. range (bidirectional)

Other configurations possible on special request.

This information applies to a product under development. Its characteristics and specifications are subject to change without notice. Hyb d.o.o. assumes no obligation regarding future manufacture unless otherwise agreed to in writing. Copyright © Hyb d.o.o., 2010. All rights reserved.