

HPSAC 3000 Pressure Transducer**General description**

Pressure transducer model HPSAC 3000 is a temperature compensated pressure sensing device with zero calibrated output.

High performance and accuracy enables use of this transducer in many applications, and with its compact and handy design is very suitable for end users. The HPSAC 3000 pressure transducers are constructed on 1 mm thick ceramic substrate with one or two pressure tubes. Thick film resistors printed on substrate are individually laser trimmed to provide temperature compensation and zero calibration. An additional resistor is trimmed according to individual transducer span to provide easy transducer amplification with external differential amplifier. Pressure media compatible with this transducer family is dry air or non-corrosive gases and liquids.

The model HPSAC 3000 is designed for constant current excitation. Whole family includes pressure ranges from 10 mbar up to 7 bar.

Features

- Constant current excitation
- Easy to use DIP package
- Wide compensated range (0 to 60°C)
- Zero calibration
- High performance OEM applications
- Differential, gage and absolute configurations
- Wide pressure range from 10 mbar up to 7 bar

Applications

- Medical instrumentation
- Respirators
- HVAC
- Process control
- Leak detection
- Pneumatic controls
- Altimeters



This information applies to a product under development. Its characteristics and specifications are subject to change without notice. Hyb d.o.o. assumes no obligation regarding future manufacture unless otherwise agreed to in writing. Copyright © Hyb d.o.o., 2010. All rights reserved.

Types overview

Pressure range	10 mbar (0.15 psi)	20 mbar (0.3 psi)	50 mbar (0.8 psi)	100 mbar (1.5 psi)
ID group	HPSAC 3000-010M	HPSAC 3000-020M	HPSAC 3000-050M	HPSAC 3000-100M
V _{OUT} ³⁾	25 to 75 mV	25 to 75 mV	25 to 75 mV	25 to 75 mV
V _{OFS(MAX)} ; 25°C	±2 mV	±2 mV	±2 mV	±2 mV
Temp. ranges	Operating: -40 to 125°C Compensated: 0 to 60°C Storage: -40 to 125°C			
Over pressure ¹⁾	100 mbar	200 mbar	500 mbar	1000 mbar
Burst pressure ²⁾	150 mbar	300 mbar	750 mbar	1500 mbar

Pressure range	350 mbar (5 psi)	1 bar (15 psi)	2 bar (30 psi)	4 bar (60 psi)	7 bar (100 psi)
ID group	HPSAC 3000-350M	HPSAC 3000-001B	HPSAC 3000-002B	HPSAC 3000-004B	HPSAC 3000-007B
V _{OUT} ³⁾	75 to 150 mV	75 to 150 mV	75 to 150 mV	75 to 150 mV	75 to 150 mV
V _{OFS(MAX)} ; 25°C	±2 mV	±2 mV	±2 mV	±2 mV	±2 mV
Temp. ranges	Operating: -40 to 125°C Compensated: 0 to 60°C Storage: -40 to 125°C				
Over pressure ¹⁾	1 bar	3 bar	6 bar	8 bar	14 bar
Burst pressure ²⁾	1.7 bar	5 bar	10 bar	12 bar	21 bar

 $T_{AMB} = 25^{\circ}\text{C}$
 $I_{CC} = 1,5 \text{ mA}$, unless otherwise noted

Performance characteristics

Parameter	Min.	Type	Max.	Unit
Input current		1.5	3.0	mA
Bridge resistance	2		4	kΩ
Thermal error of span (0 to 60°C) ^{5), 6)}		±0.2	±0.5	%FS
Thermal error of offset (0 to 60°C) ^{4), 6)}		±0.2	±0.5	%FS
Combined linearity and hysteresis ⁸⁾		±0.2	±0.5	%FS
Input impedance	2		4	kΩ
Output impedance	2.7		4	kΩ
Repeatability ⁷⁾		±0.05		%FSO
Long term stability of offset and span		±0.1		mV
Media compatibility	See spec. note ^{9), 10)}			
Weight		2		g

This information applies to a product under development. Its characteristics and specifications are subject to change without notice. Hyb d.o.o. assumes no obligation regarding future manufacture unless otherwise agreed to in writing. Copyright © Hyb d.o.o., 2010. All rights reserved.

Specification notes

- 1) Over pressure is the maximum pressure which may be applied without causing damage to the sensing element.
- 2) Burst pressure is the maximum pressure which may be applied without causing leakage damage to the sensing element.
- 3) Analog output signal is ratiometric to input current supply I_{CC} .
- 4) Offset voltage is the voltage output at zero pressure.
- 5) Span is the algebraic difference between the output at full scale pressure range and offset.
- 6) Thermal error of span and offset represents the maximum deviation of transducer signal (span and offset) through whole compensated temperature range from 0 to 60°C in compare to value at 25°C.
- 7) Repeatability is defined as typical deviation of the output signal after 10 pressure cycles.
- 8) Nonlinearity is defined as the BFSL (best fit straight line) across entire pressure range.
- 9) Media compatibility: on pressure port P1: clean, dry and noncorrosive gases to silicon, RTV, gold, ceramics Al_2O_3 , epoxy, nickel.
- 10) Media compatibility: on pressure port P2: noncorrosive gases or liquids to silicon, Pyrex, RTV, ceramics Al_2O_3 , epoxy, nickel.

Outline dimensions and pinout

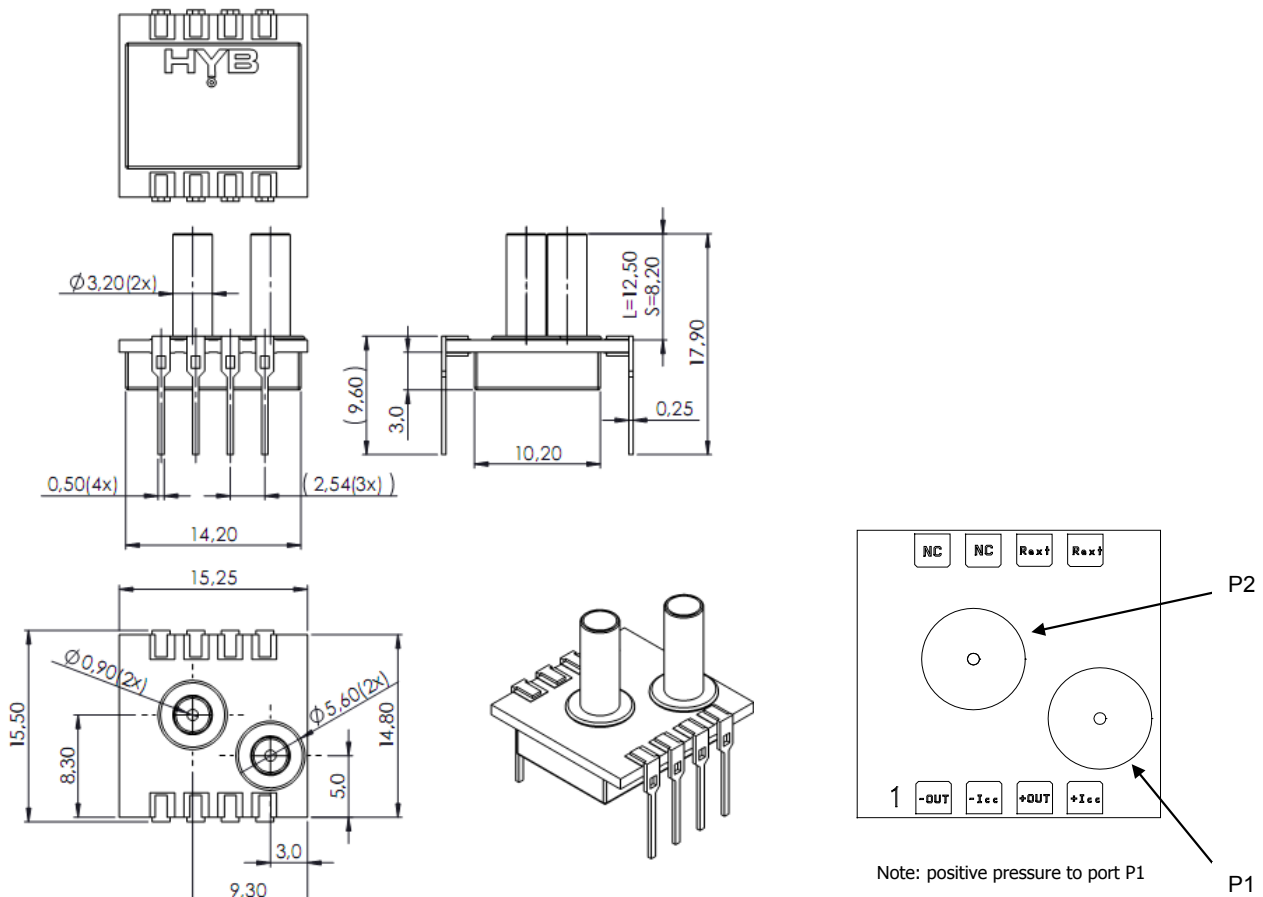

This information applies to a product under development. Its characteristics and specifications are subject to change without notice. Hyb d.o.o. assumes no obligation regarding future manufacture unless otherwise agreed to in writing. Copyright © Hyb d.o.o., 2010. All rights reserved.

HPSAC 3000 Pressure Transducer

Application example

HPSAC 3000

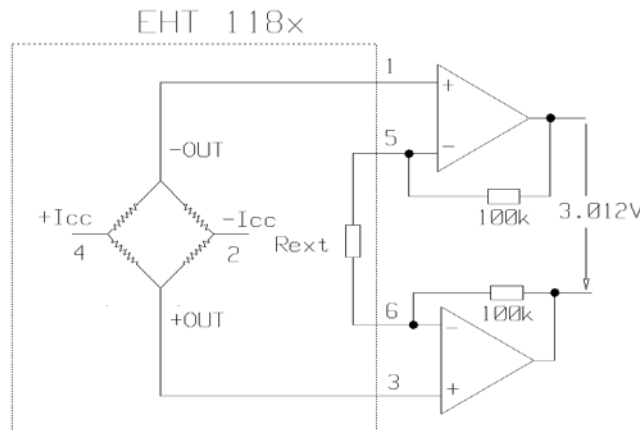

Ordering guide

Transducer type	Pressure range	Pressure type	Pressure port
HPSAC 3000	010M	D	L
	020M	G	S
	050M	A	0
	100M		
	350M		
	001B		
	002B		
	004B		
	007B		

Pressure range	
010M	10 mbar
020M	20 mbar
050M	50 mbar
100M	100 mbar
350M	350 mbar
001B	1 bar
002B	2 bar
004B	4 bar
007B	7 bar

Pressure type	
D	Differential
G	Gage
A	Absolute (for p ≥ 1 bar)

Pressure port	
L	Long
S	Short
0	without ports

Other configurations possible on special request.

This information applies to a product under development. Its characteristics and specifications are subject to change without notice. Hyb d.o.o. assumes no obligation regarding future manufacture unless otherwise agreed to in writing. Copyright © Hyb d.o.o., 2010. All rights reserved.