

## General description

Pressure transducer model HPSAC 2000 is a pressure sensing device with temperature compensation of offset and span with included zero calibration.

High performance and accuracy enables use of this transducer in many applications, and with its compact and handy design is very suitable for OEM users. The HPSAC 2000 pressure transducers are constructed on 1 mm thick ceramic substrate attached inside standard metal 19 mm housing with O-ring groove. Housing material is either aluminium or stainless steel. Thick film resistors printed on substrate are individually laser trimmed to provide temperature compensation and zero calibration.

The model HPSAC 2000 is designed for constant current excitation. Whole family includes 20 mbar up to 7 bar pressure range.

## Features

- Constant current excitation
- Easy to use package
- Compensated range (0 to 50°C)
- Industrial temperature operating range (-25 to 85°C)
- Low zero offset voltage
- High performance OEM applications
- Gage configurations

## Applications

- Medical instrumentation
- Respirators
- Air flow monitoring
- Process control
- Leak detection
- Pneumatic controls
- Altimeters



This information applies to a product under development. Its characteristics and specifications are subject to change without notice. Hyb d.o.o. assumes no obligation regarding future manufacture unless otherwise agreed to in writing. Copyright © Hyb d.o.o., 2010. All rights reserved.

## Types overview

Pressure range	20 mbar (0.3 psi)	50 mbar (0.8 psi)	100 mbar (1.5 psi)
ID group	HPSAC 2000-020M	HPSAC 2000-050M	HPSAC 2000-100M
V <sub>OUT</sub> <sup>3)</sup>	8 to 75 mV	8 to 75 mV	8 to 75 mV
V <sub>OFS(MAX)</sub> <sup>3), 5)</sup>	±1 mV	±1 mV	±1 mV
Temp. ranges	Operating: -25 to 85°C Compensated: 0 to 50°C Storage: -40 to 125°C		
Over pressure <sup>1)</sup>	60 mbar	150 mbar	300 mbar
Burst pressure <sup>2)</sup>	100 mbar	250 mbar	500 mbar

Pressure range	350mbar (5 psi)	1bar (15 psi)	2bar (30 psi)	4bar (60 psi)	7bar (100 psi)
ID group	HPSAC 2000-350M	HPSAC 2000-001B	HPSAC 2000-002B	HPSAC 2000-004B	HPSAC 2000-007B
V <sub>OUT</sub> <sup>3)</sup>	25 to 140 mV	45 to 125 mV	45 to 140 mV	60 to 140 mV	60 to 140 mV
V <sub>OFS(MAX)</sub> <sup>3), 5)</sup>	±1 mV	±1 mV	±1 mV	±1 mV	±1 mV
Temp. ranges	Operating: -25 to 85°C Compensated: 0 to 50°C Storage: -40 to 125°C				
Over pressure <sup>1)</sup>	1 bar	3 bar	6 bar	8 bar	14 bar
Burst pressure <sup>2)</sup>	1.7 bar	5 bar	10 bar	12 bar	21 bar

 $T_{AMB} = 25^{\circ}\text{C}$ 
 $I_{cc} = 1 \text{ mA}$ , unless otherwise noted

## Performance characteristics

Parameter	Min.	Type	Max.	Unit
Input current		1	3	mA
Thermal error of span (0 to 50°C) <sup>4)</sup>		±1	±2	%FS
Thermal error of offset (0 to 50°C) <sup>4)</sup>		±0.3	±1	mV
Combined linearity and hysteresis <sup>5)</sup>		±0.2	±0.5	%FS <sup>2</sup>
Repeatability <sup>7)</sup>		±0.05		%FSO
Input impedance	2		4	kΩ
Output impedance	2.7		4	kΩ
Media compatibility	See spec. note <sup>8)</sup>			

This information applies to a product under development. Its characteristics and specifications are subject to change without notice. Hyb d.o.o. assumes no obligation regarding future manufacture unless otherwise agreed to in writing. Copyright © Hyb d.o.o., 2010. All rights reserved.

### Specification notes

- 1) Over pressure is the maximum pressure which may be applied without causing damage to the sensing element.
- 2) Burst pressure is the maximum pressure which may be applied without causing leakage damage to the sensing element.
- 3) Analog output signal is ratiometric to power supply  $I_{CC}$ .
- 4) Thermal error of offset and span is presented as max error over complete compensated temperature range in compare to nominal value at 25°C.
- 5) Offset voltage is the voltage output at zero pressure.
- 6) Nonlinearity is defined as the BFSL (best fit straight line) across entire pressure range.
- 7) Repeatability is defined as typical deviation of the output signal after 10 pressure cycles.
- 8) All noncorrosive gases and liquids to pyrex, silicon, RTV, ceramics  $Al_2O_3$ , epoxy, stainless steel.

### Outline dimensions

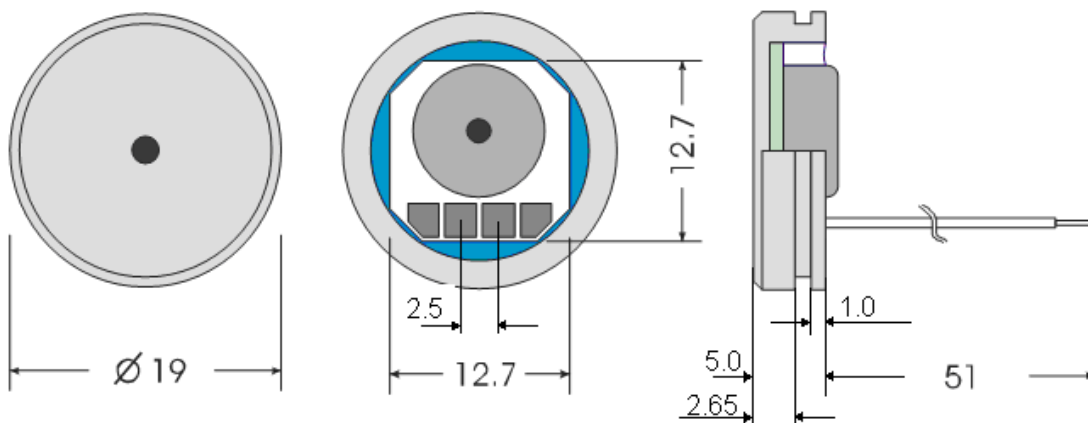

### Pinout



- 1 – Negative OUT <sup>1)</sup>
- 2 – Positive OUT <sup>1)</sup>
- 3 – Negative IN
- 4 – Positive IN

<sup>1)</sup> – Positive output for positive pressure from bottom side.

This information applies to a product under development. Its characteristics and specifications are subject to change without notice. Hyb d.o.o. assumes no obligation regarding future manufacture unless otherwise agreed to in writing. Copyright © Hyb d.o.o., 2010. All rights reserved.

Ordering guide

Transducer type	Pressure range	Pressure type
HPSAC 2000	020M	G
	050M	
	100M	
	350M	
	001B	
	002B	
	004B	
	007B	

Pressure range	
020M	20 mbar
050M	50 mbar
100M	100 mbar
350M	350 mbar
001B	1 bar
002B	2 bar
004B	4 bar
007B	7 bar

Pressure type	
G	Gage

Other configurations possible on special request.

This information applies to a product under development. Its characteristics and specifications are subject to change without notice. Hyb d.o.o. assumes no obligation regarding future manufacture unless otherwise agreed to in writing. Copyright © Hyb d.o.o., 2010. All rights reserved.